

## Egenskaber

- » Nem installation
- » Nem håndtering og transport på grund af lav vægt og medfølgende transportkasse
- » Idéel for brug i områder uden strøm.
- » Drifttid: 25 minutter ved maksimal belastning .
- » Leveres med ekstra batteri og oplader.
- » Svirvellastkrog med pal.
- » Leveres med styretryk og kædepose.
- » Overholder Maskindirektivet 2006/42/EF. Leveres med testcertifikat, CE-overensstemmelses erklæring og brugermanual.

## Features

- » Fast installation.
- » Easy handling and high transportability due to low weight and carrying case.
- » Ideal for applications without power supply.
- » Battery power: 25min at maximum load.
- » Delivered with spare battery and charger.
- » Swivel load hook with safety latch.
- » Supplied ready to use with control switch and chain container.
- » Complies with the Machinery Directive 2006/42/EC. Supplied with test certificate, CE declaration of conformity and operating instructions.



Specifikationer / Specifications							
Artikelnummer	Kapacitet (WLL)	Løftehøjde	Hastighed	Lastkæde	Antal kædestreng	Energiforbrug	Egenvægt
Article code	Capacity (WLL)	Hoisting height	Lifting speed	Load chain	Chain falls	Power output	Net weight
	ton	m	m/min	Øxmm		kW	kg
501700001	0.25	10	4.5	4 x 12	1	-	12
501700002	0.5	5	2.2	4 x 12	2	-	13.5

Specificaties / Specifications	
Driftsspænding / Operating voltage	18V (5.0Ah 90Wh) genopladeligt li-ion batteri / 18V (5.0Ah 90Wh) rechargeable li-ion battery
Hejsehastighed / Lifting speed	Variabel (ved sænkning) / Variable speed (when lowering)
Lastkæde / Load chain	Galvaniseret lastkæde i henhold til EN 818-7 / Galvanized load chain according to EN 818-7
Styrekabel / Control cable	Standard ≈3 meter / Standard ≈3 meter
Strømkabel / Power cable	-
Beskyttelse for taljehus / Housing protection	IP 54
Beskyttelse for styretryk / Control protection	IP 50
Klassificering / Classification	M4/1Am (ISO/FEM)
Driftcyklus / Start pr. time / Duty cycle / Starts per hour	30% / 180
Isoleringsklasse / Insulation class	F
Drifttemperatur / Operating temperature	-10°C - +40°C
For byrde / Load type	Kun for løft af materialer ikke godkendt til løft af personer / Goods only, may not be used to lift people

Beskyttelse / Protection	
Kontrolafbryder / Control switch	Styrkebetjening med nødstop / Pendant control switch with emergency stop button
Overlastsikring / Overload protection	Udvendigt indstilling glidekobling samt digital sikring / Externally adjustable slip clutch and digital protection
Bremse / Brake	Mekanisk bremse / Mechanical brake
Endestopkontakt / Limit switch	Elektromagnetisk top og bund beskyttet af glidekobling. / Electromagnetic upper limit switch, lower limit protected through slip clutch
Termisk beskyttelse / Thermal protection	Ingen beskyttelse / No protection

### Batteridrevet eltalje / Battery Chain Hoist

Transport kasse / Carrying case		
Kapacitet / Capacity	Total vægt* / Total weight *	Diimensioner / Dimensions
ton	kg	mm
0.25	20.3	640 x 420 x 280
0.5	23.2	

\* inklusiv alle accessories og standard hejsehøjde / including all accessories and standard hoisting height

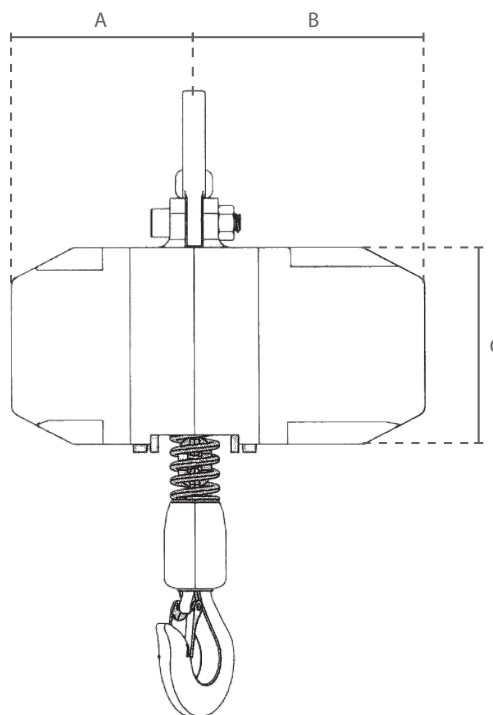
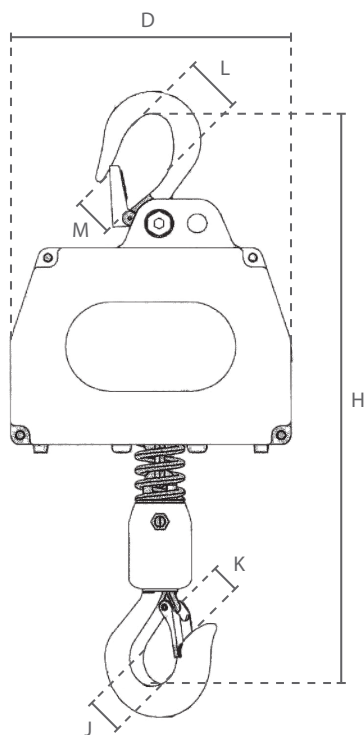

Varenummer / Article code	Dimensioner / Dimensions									
	A	B	C	D	H	J	K	L	M	
501700001	114	144	122	173	355	29	19	27	20	
501700002	114	144	122	173	375	29	19	27	20	